



*Esoteric
Audio
Devices*



EAD E100

Embracing a range of almost nine octaves, the E100 offers among the widest bandwidth of any single drive unit available. This not only provides an exceptionally smooth, high-definition, crossover-free sound quality but allows for a very diverse range of applications.

The E100 can be successfully used with all types of enclosures including closed or vented boxes, transmission lines and horn loaded designs. It is eminently suitable for professional near-field monitors, high quality domestic hi-fi, home cinema and custom installations. Optionally the unit is magnetically screened, enabling it to be used in close proximity. (The shield is a separate item that can be added at any time.)

Note, parameters and curves are subject to changes:

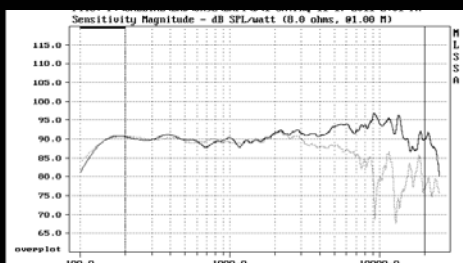
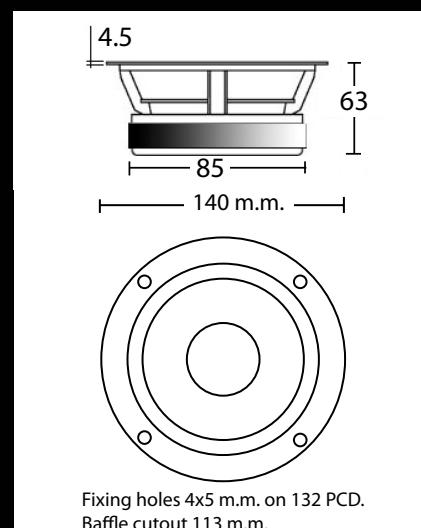

Frequency

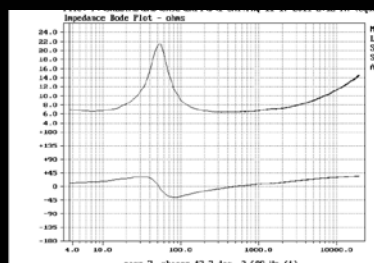

Impedance & Phase

Technical specifications

15min break-in at 9volts 50 Hz. Stimulus level 3.83 Volts.

Free air resonance FO	Hz	51.0
Mechanical Q	Qm	1.86
Electrical Q	Qe	0.69
Total Q	Qt	0.50
Force factor	B*1 t*m	4.17
DC resistance	Re ohms	5.53
Dynamic mass	Md grams	6.7
Cms	æM/Newton	1443
Equiv air volume	Vas litre	12.51
Cone area	Sd sq. cms	78.5
Sound pressure level	SPL 1m 1w	87.3
Min box volume (1B)	litres	3.0
Power, continuous	watts	50
Power, music, in system	watts	100
Xmax p-p	m.m.	9.0

v 1.2 Last updated 2012-08-30

