



Esoteric

Audio

Devices



EAD E130

PRELIMINARY BROSHURE!

Nothing is so good that it can't be improved!
E130 has gone through a second face lift. Most noticeable is the new taylored aluminum chassis.

Then we added a new rim, spider, motor and a new stronger glue. This gave us a design that can take a lot of "abuse" with a more linear behaviour. The new motor now gives us an 89dB sensitivity, and a range from 35Hz up to around 19Khz, making it almost a full range 6.5" bass unit which can be easily combined with a number of tweeters in a 2-way system, or even used as a single unit, (but a 2 way system is recommended). In combination with our new E60, you get numerous crossover options from 120 to 2,5Khz.

Why not try a linear array of 4, 9 or even 16x E60

units for example?

We kept the dual coil and made Qt lower (0.46 in 80hm).

For the advanced designer the dual coil gives a number of options, firstly by connecting the two coils in single, series or parallel mode (16,8 or 32 Ohm), but then also when connecting multiple drivers from 2 to endless linear arrays. By shortening one coil with a resistor for example, you can also get even more options, controlling the Q. (Qts will come down to almost half by simply shortening the second coil).

E130 now also comes with individual parameters included in each box!

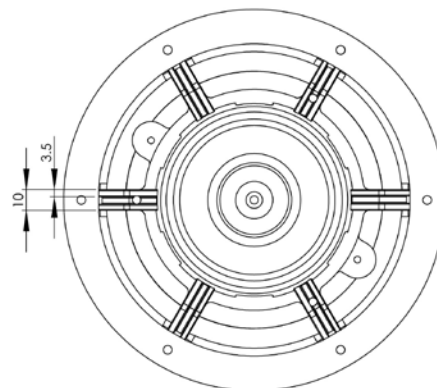
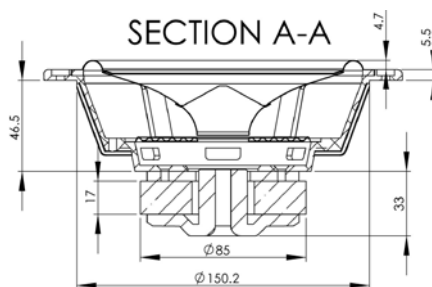
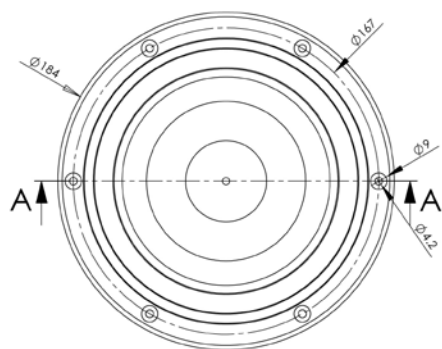

v1.0



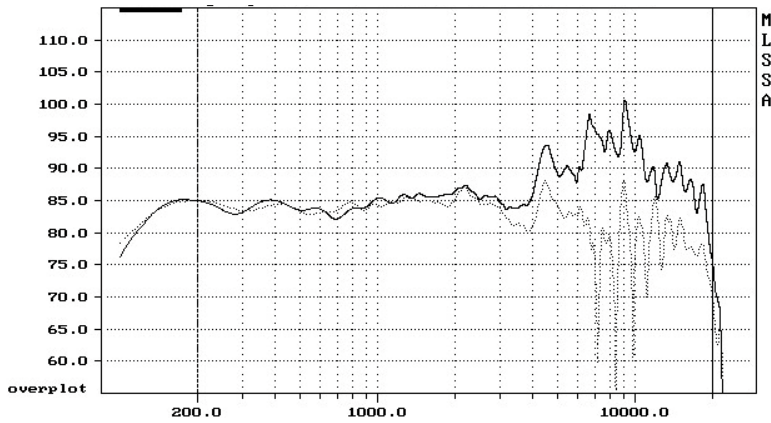

Frequency

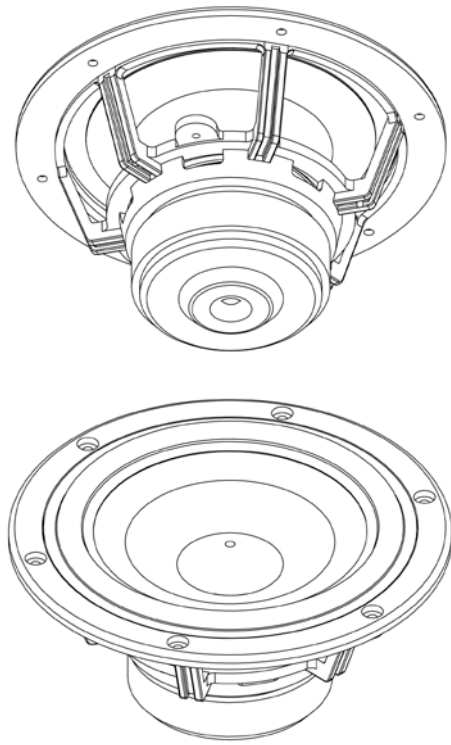

Parameters

Thiele/Small Parameters, 1 coil (16 ohm)	Thiele/Small Parameters, 2 coils in parallel (8 ohm)	Thiele/Small Parameters, 2 coils series (32 Ohms)
"Title: Measured Parameters"	"Title: Measured Parameters"	"Title: Measured Parameters"
"Method: Fixed-Mmd (11.000 grams)"	"Method: Fixed-Mmd (11.000 grams)"	N/A Will come soon.
"DCR mode: Fixed (12.20 ohms)"	"DCR mode: Fixed (6.20 ohms)"	
"Area (Sd): 138.93 sq cm"	"Area (Sd): 138.93 sq cm"	
"Series resistance: 75.00 ohms"	"Series resistance: 75.00 ohms"	
"Stimulus level: 3.83 volts"	"Stimulus level: 3.83 volts"	
"SPLref reference impedance: 8 ohms"	"SPLref reference impedance: 8 ohms"	
"Large units (volume = liters, mass = grams)"	"Large units (volume = liters, mass = grams)"	
0.987 "RMSE-free Ohms"	0.890 "RMSE-free Ohms"	
35 "Fs Hz"	35 "Fs Hz"	
12.200 "Re Ohms"	6.200 "Re Ohms"	
48.799 "Res Ohms"	48.555 "Res Ohms"	
3.721 "Qms "	3.647 "Qms "	
0.930 "Qes "	0.466 "Qes "	
0.744 "Qts "	0.413 "Qts "	
0.144 "L1 mH"	0.121 "L1 mH"	
2.000 "L2 mH"	1.816 "L2 mH"	
4.030 "R2 Ohms"	4.019 "R2 Ohms"	
0.000 "RMSE-load Ohms"	0.000 "RMSE-load Ohms"	
45.048 "Vas(Sd) liters"	45.607 "Vas(Sd) liters"	
11.927 "Mms(Sd) grams"	11.927 "Mms(Sd) grams"	
1661.746 "Cms(Sd) æM/Newton"	1682.354 "Cms(Sd) æM/Newton"	
5.928 "Bl(Sd) Tesla-M"	5.954 "Bl(Sd) Tesla-M"	
83.446 "SPLref(Sd) dB "	89.363 "SPLref(Sd) dB[8 ohms]"	
0.007 "Rub-index "	0.007 "Rub-index "	
X-max +/- 6.3mm (12.6 m.m. p-p)	X-max +/- 6.3mm (12.6 m.m. p-p)	X-max +/- 6.3mm (12.6 m.m. p-p)
Power 60W cont. 100W Max. In music	Power 60W cont. 100W Max. In music	Power 60W cont. 100W Max. In music

Test conditions:

Break in : 15min at 10V at resonance.

Equipment : MLSSA 10 WI Rev 8 with RCAI Box

Stimulus level for Parameter measurement : 3.83 V and 2.83 V for SPL.

Frequency plot (2 pi measurement) in flat baffle. Anechoic chamber 4 mtr width x 3 mtr depth. Walls lined up with 1 1/2' high density glass wool wedges.

Microphone : G.R.A.S. 1/2" Free Field Microphone 40AC with Preamp 26AK and Power module: 12AK

Temperature : 24 deg C, Humidity 80%

Fs Method : Fixed Mass

All parameters are preliminary and subject to change.